

# dickinson

SINCE 1932

Dickinson Marine  
#407-204 Cayer St Coquitlam  
BC Canada V3K 5B1  
[www.dickinsonmarine.com](http://www.dickinsonmarine.com)  
[info@dickinsonmarine.com](mailto:info@dickinsonmarine.com)  
T: 800 659 9768



# SPITFIRE MARINE GRILL 180 PROPANE BARBECUE

---

## Operator's Manual

This manual must be read and the requirements carried out to ensure satisfactory performance.

DICKINSON RESERVES THE RIGHT TO MAKE CHANGES TO PRODUCTS OR DOCUMENTS AT ANY TIME

QUALITY INSPECTED BY- Doug & Don

DATE- Nov 5/2008







## Contents



### Spitfire 180

- Top Lid and Main Body Assembly
- Thermometer, Burner Assy, and Regulator
- Stainless Grill
- Deck Leg Feet
- Drip Tray
- Manual c/w Warranty Form

## Warnings and Disclosures

Follow all installation and operating procedures.

	<b>The spitfire 180 is designed for lpg only</b>
	<b>IMPORTANT:</b> Read this owner's manual carefully and completely before trying to assemble, operate, or service this barbeque. Improper use of this gas appliance can cause serious injury or death from burns, fire, explosion, carbon monoxide poisoning and oxygen depletion.
	<b>WARNING:</b> Do not install this appliance in spaces containing internal combustion engines, their fuel tanks, or joints and fittings of their fuel systems.
	Test all propane lines and connections for leaks with a soapy water solution. Do not flame test for leaks.
	<b>WARNING:</b> If the information in this manual is not followed exactly, a fire or explosion may result causing property damage, personal injury, or loss of life. — Do not store or use gasoline or other flammable vapors and liquids in the vicinity of this or any other appliance. <ul style="list-style-type: none"><li>• Do not try to light any appliance.</li><li>• Do not touch any electrical switch..</li></ul>
	Close the lpg cylinder valve when Bar-b-que is not in use

	Close the lpg cylinder valve in the event of an emergency
	Close the Bar-b-que regulator valve before opening the lpg cylinder valve
	Save this manual for future reference.

## Bar-b-Que Feet Assembly Instructions

Most of the assembly for your new BBQ has been done for you. You will need to attach the feet of the BBQ to the rest of the unit. The two feet of the Sea-B-Que slide on to the inserted studs on the base. The flanges are to point outwards. Use the four 10 x 32 nuts and #10 lock-washers to secure the legs to the base.

## Regulator Control & Propane Fuel Supply

Propane must be supplied from a standard or disposable propane bottle. **High** pressure propane is required. The sea-b-que gas control is also the pressure regulator. If your boat has a regulated propane source the fuel line to the Sea-b-que must be T'd off before any regulators on the main fuel supply. The T type connector is available from Dickinson for this purpose (# 15-178). If replacing the regulator control or the Sea-b-Que is not getting hot enough even after the venturi has been adjusted, the regulator may need to be adjusted. If so use a bottle that is more than ½ full and light the burner and turn the control on high, peel the shiny sticker off the front of the control knob. There will be a Phillips screw or a 5/64 Allen screw. Turn clockwise to increase the flame, at about ½ turn at a time (no more than 2 full turns).

**NOTE-** this will affect the low setting as well. If decreasing the flames, turn the screw counterclockwise in small increments to make sure the flames do not go out on the low setting on a windy day. Use the new sticker to cover the adjusting screw after you are sure it is adjusted to your liking.

**WARNING** - The new regulator may have a set screw located at the opposite end of the fuel outlet. This is for manufacturing purpose and should not be opened as full high pressure propane **will** exhaust.

For sticker replacements contact

[info@dickinsonmarine.com](mailto:info@dickinsonmarine.com)

## **Thermometer**

The Spitfire 180 is fitted with a thermometer. If you remove the thermometer for cleaning or replacement, refer to Diagram E for re-assembly.

Inspect the thermometer to ensure no small white bits of plastic are around the edge, left over from the protective plastic used in the manufacturing process.

Be aware that bending or damaging the thermometer probe or dropping the Bar-b-Que, may cause the thermometer to stop working.

## **Igniter**

The igniter probe should be as close to the holes in the burner as possible. See Diagram C. For a perfect fit, adjust the probe so that it is 3/16ths“(4.75mm) away from the holes.

Igniters seldom fail but if yours stops working try cleaning the probe. Built up grease may have coated the probe, preventing the spark. Remove the igniter, clean the bracket and around the BBQ base, the copper line on the side of the igniter and the screws. Built up grease may have interrupted the ground.

## **Orifice Assembly**

The orifice assembly is the series of brass fittings that attach to the gas regulator control and go to the inside of the end of the burner. The orifice has a tiny hole that controls the maximum amount of fuel into the burner. From time to time salt or other debris may plug the hole changing the flame and / or the Sea-B-Que will not get hot, and a blocked orifice may be the reason. Remove and clean with a very small wire like the kind in a (twist tie). Do not expand the hole or the Sea-b-Que will get too hot.

## **The Burner**

Your Burner bar is made of stainless steel and is the most rugged, longest lasting marine burner bar around. Salt air, heat and acids in foods however still take their toll on the burner bar. Try to keep the burner clean and free of obstructions. The venturi may need adjusting to your liking. When the slots line up the flame will be vibrant blue ( more like a broiler flame ), and when the slots are closed the flame will be lazy yellow (more like a burning briquette bbq), or just left in the middle.

## **Mounting**

**Important Note:** Barbecues get hot and will splash, leak grease, and for safety reasons it is therefore advisable to mount the unit outboard.

## Optional Mounting

#15-150A	Rail Kit
#15-150F	Fishing Rod Holder Mount Kit
#15-187	Taff Rail Kit
#15-150P	Scotty Mount Kit

Visit [www.dickinsonmarine.com](http://www.dickinsonmarine.com) for pics and details

## Low pressure Retrofit

The control on the Bar-b-Que will need to be changed to a low pressure control (#15-193), and a low pressure (11" water column) regulator (#19-151) needed for the propane tank.

## Cooking

The removable drip tray must be installed prior to cooking. Do not allow grease to build-up in the grease tray or in the base of the sea-b-que. The stainless steel grill should be sprayed or covered with cooking oil to prevent food from sticking. Accumulated grease will burn off if the cooking grill is turned over.

## Diagrams

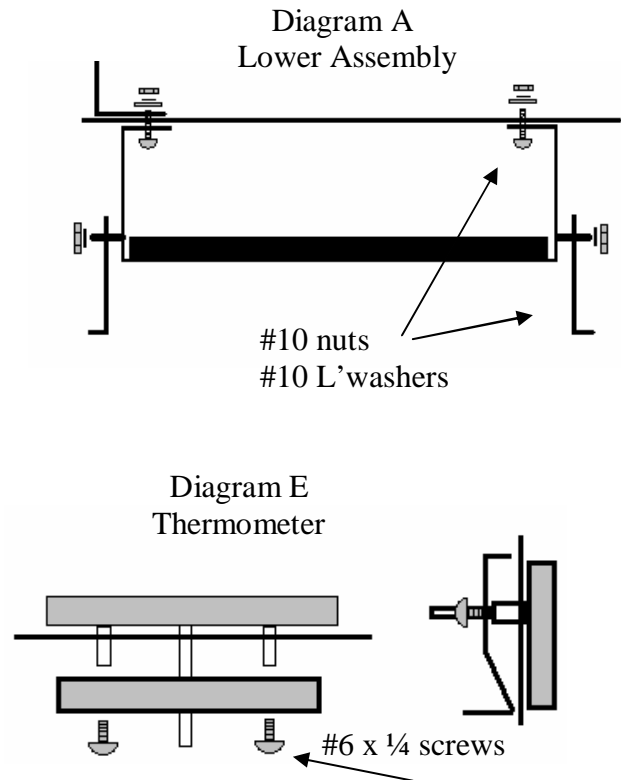
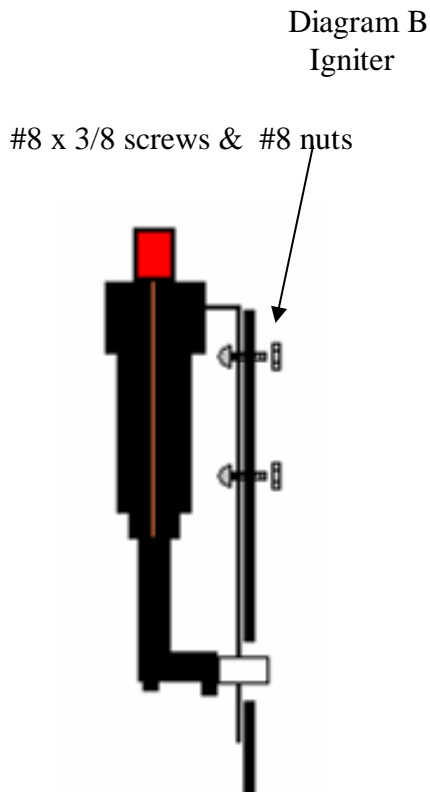

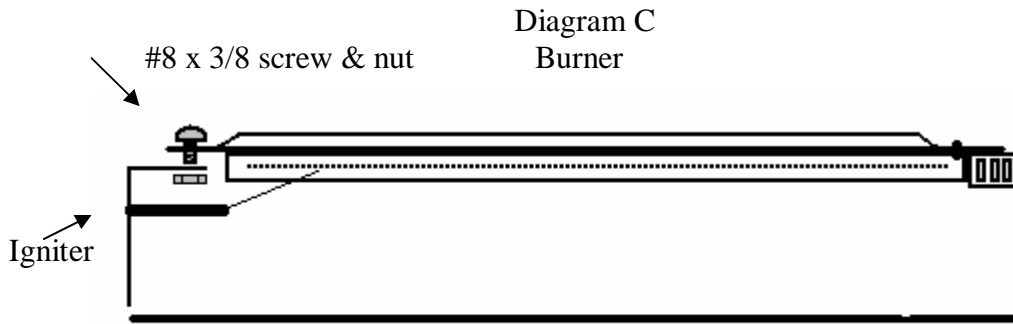

## Accessories

#15-171	Cover
#15-203	Aussie griddle
#15-196	Stainless Steel Grill
#15-080	Drip Tray
#15-061	Burner
#15-073	Orifice
#15-101	Igniter
#15-110	Regulator Control
#15-193	Retrofit <b>Low</b> pressure Control
#19-151	Retrofit <b>Low</b> pressure Regulator
#15-120	Thermometer
#15-194	Adapter for European Gas Canisters (High Pressure)

## Hoses

#15-188	6 ft. Propane Hose ( Certified connections – <b>High</b> Pressure)
#15-189	8 ft. Propane Hose ( Certified connections – <b>High</b> Pressure)
#15-191	6ft. Propane T Type Hose ( Certified connections – <b>High</b> Pressure)
#15-192	8ft. Propane T Type Hose ( Certified connections – <b>High</b> Pressure)
#15-178	“T” type Connector ( To adapt a high pressure fuel line to an onboard <b>Low</b> pressure system).
#19-100-10	10 ft. <b>Low</b> Pressure Hose ( Certified connections )
#19-100-20	20 ft. <b>Low</b> Pressure Hose ( Certified connections )

**Test all propane lines and connections for leaks with a soapy water solution before lighting. Do not flame test for leaks.**

## Lighting

- 1) Bar-B-Que control regulator in LOCK-OFF position
- 2) Open Lid and turn on LPG gas supply at source
- 3) Turn Control Regulator ON to the medium level. Press Igniter several times, or use a long bbq lighter. Check to make sure the propane is burning.

## Warnings

**If the burner does not light immediately turn control regulator to lock-off position and do not attempt to light the burner for at least 60 seconds**

**Close the lpg cylinder valve when sea-b-que is not in use**

**Close the lpg cylinder valve when the boat is unattended**

**Close the lpg cylinder valve in the event of an emergency**

**Close the sea-b-que regulator valve before opening the lpg cylinder valve**

## Operation

When the burner is lit the Control Regulator setting may be selected. With the lid closed the Bar-B-Que will quickly reach cooking temperatures (5 minutes).

Do not leave the control regulator at high and the lid closed for long periods of time or damage may be caused to the Bar-b-que. High gas settings are only recommended for a short pre-heat period and barbequing with the lid open, or lid closed but at a moderate setting. After cooking turn the Bar-B-Que off at the LPG source. Once the burner has extinguished turn the Control Regulator to the LOCK-OFF position. This will depressurize the fuel line.

## Cleaning and Maintenance

- 1) Clean grease from the drip tray and the base of the Bar-B-Que regularly
- 2) Clean burner and burner orifice seasonally. The burner orifice can be removed for thorough cleaning with hot water and a bronze wire brush.
- 3) Stainless Bar-B-Que top lid and main body will discolor with the heat. Stainless steel has a chromium layer that makes it corrosion resistant. When the metal is heated more of the chrome reacts with the oxygen in the atmosphere and becomes this chromium oxide. The discoloration is a by-product but it is not rust or corrosion. An acidic compound known as pickling paste can remove the tinting.

- 4) The marine environment can take a harsh toll on all stainless steel bar-b-ques. The Sea-B-Que is made of high quality #304 stainless steel however the chlorine and sodium chloride in the ocean water mixed with the heat of the Sea-b-que creates a small surface corrosion. It is therefore recommended to keep up with regular cleaning and maintenance to keep your Sea-B-Que in pristine condition. The use of oven cleaner to remove cooking stains and the use of a non-metallic abrasive pad such as scotch Brite pads on the exterior surface is also recommended. Stainless steel Polish if available will also enhance the look of your Sea-B-Que. Rubbing the surface of the stainless steel with the grain will remove the rusty appearance and will keep your Sea-B-Que looking shiny and new for many years to come.

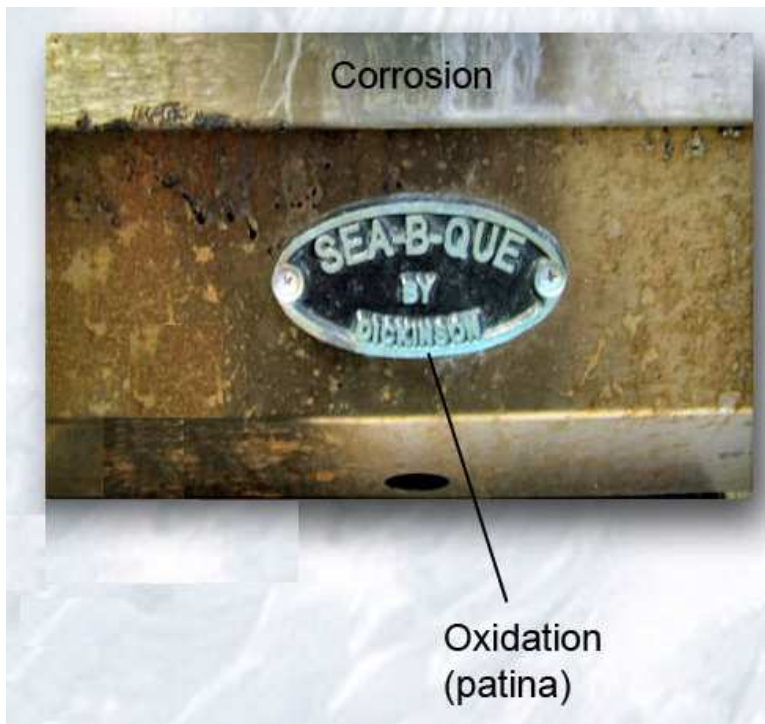

- 5) Igniter: A defective igniter is uncommon. If the igniter does not work it will be caused by grease build-up on the wire electrode OR the igniter mount is not grounded to the body of the barbecue during assembly. The igniter can be cleaned with hot water and a cloth.

## Limited Warranty

**WARRANTY PROVISIONS** : Dickinson warrants this product to be free of defects in workmanship and materials for a period of one year. This warranty is limited to claims submitted in writing within a one-year period following the date of purchase. If any part of your new product fails because of a manufacturing defect within the warranty period Dickinson offers to replace said parts free of charge, provided, however, that such parts have not been improperly repaired, altered or tampered with or subjected to misuse, abuse or exposed to corrosive conditions. This warranty, however, is limited by certain exclusions, time limits and exceptions as listed below. Read these limitations and exclusions carefully.

**TIME LIMIT** : This warranty is given too and covers only the original purchaser. Coverage terminates one year from the date of purchase for parts replacement. **EXCLUSIONS** : This warranty does not cover or include : (a) Any normal deterioration of the product and appearance of items, due to wear and/or exposure; (b) any guarantees, promises, representations, warranties or service agreements given or made by an authorized distributor or other person selling this product, other than those specifically stated herein; (c) any damage or defect due to accident, improper repair, alteration, unreasonable use including failure to provide reasonable and necessary maintenance, misuse or abuse of the equipment, or exposure to corrosive conditions. This warranty is conditioned upon normal use, reasonable and necessary maintenance and service of your product, and written notice being given promptly upon Buyer's discovery of a warranty claim, pursuant to paragraph 6 below. Reasonable and necessary maintenance is maintenance which you are expected to do yourself or have done for you. It is maintenance, which is necessary to keep your product performing its intended function and operating at a reasonable level of performance.

**DAMAGE LIMITATION WARNING** : IN NO EVENT SHALL Dickinson BE LIABLE FOR ANY INCIDENTAL OR CONSEQUENTIAL DAMAGES, INCLUDING (BUT NOT LIMITED TO) LOSS OF USE OF THE PRODUCT, LOSS OF TIME, INCONVENIENCE, EXPENSES FOR TRAVEL, LODGING TRANSPORTATION CHARGES, LOSS BY DAMAGE TO PERSONAL PROPERTY OR LOSS OF INCOME, PROFITS OR REVENUE.

**ORAL OR IMPLIED WARRANTY LIMITATIONS** : The foregoing warranty is exclusive and in lieu of all other warranties, written or oral, expressed or implied, including but not limited to any warranty or merchantability or fitness for a particular purpose.

**TRANSFER LIMITATIONS** : This warranty is not assignable or transferable. It covers only the original purchaser.

**CLAIM PROCEDURE** : In the event of a defect, problem or that a breach of this warranty is discovered, in order to protect any warranty rights you must promptly notify Dickinson. Give name, address, and model name, location of unit, description of problem and where you can be reached during business hours.

**RESERVED RIGHT TO CHANGE** : Dickinson reserves the right to make changes or improvements to products it produces in the future without imposing on itself any obligations to install the same improvements in the products it has previously manufactured.

**SECOND OR SUBSEQUENT OWNER** : Dickinson does not give any warranty to secondary or subsequent purchasers, and it disclaims all implied warranties to such owners.

**INSPECTION** : To assist you in avoiding problems with your product and to validate this warranty you are required to do the following : (a) read the warranty; (b) inspect the product. Do not accept delivery until you have examined the product with your supplier; (c) ask questions about anything you do not understand concerning the product.

**OWNER REGISTRATION** : Fill out the WARRANTY CARD within 30 days from the date of delivery.

**WARRANTY : RETURN OF THE CARD IS CONDITION PRECEDENT TO WARRANTY COVERAGE AND PERFORMANCE. IF YOU DO NOT FILL OUT AND MAIL THE CARD AS DIRECTED, YOU WILL NOT HAVE A WARRANTY.**

**LEGAL RIGHTS** : This warranty gives you specific legal rights and you may also have other rights, which may vary within different government jurisdictions.

Return to:



SINCE 1932

#407 – 204 Cayer Street, Coquitlam, B.C. Canada V3K 5B1

**WARRANTY FORM**

I have read and understand the Limited Warranty and the Instruction Manual and agree to the terms and condition

(please print)

Date.....

Purchaser's Name.....

Address.....

.....

Model Name.....**Spitfire 180 Bar-b-Que**.....

Serial Number.....

Date Of Purchase.....

Signature.....

Name of Seller.....

Seller Location.....

Note: The warranty form can be filled out and sent from the website: [www.dickinsonmarine.com](http://www.dickinsonmarine.com)